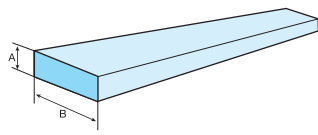
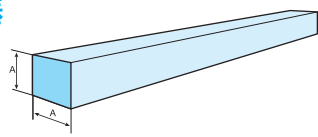
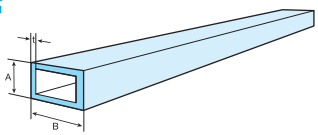
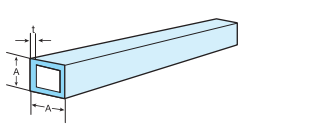

● 平角棒	寸 法			単位質量 (kg/mt)
	A	B		
 A6063 T5 長さ > 4,000	5	70		0.952
	12	120		3.917
	20	100		5.440
	25	80		5.440
	30	65		5.304
	40	75		8.160
● 四角棒	A	A		
 A6063 T5 長さ > 2,000	60	60	L=4,000	9.792
	70	70		13.32
	80	80		17.408
	100	100		27.200
● 平角管	A	B	t	
 A6063 T5 長さ > 5,000	30	100	2.5	1.700
	50	150	3	3.166
	60	120	2.8	2.638
● 角管	A	A	t	
 A6063 T5 長さ > 5,000	30	30	1.5	0.465
	100	100	3	3.166

● チャンネル A6063 T5

Rなし	チャンネル (※は R 付) L=5,000				B2 付チャンネル L=3,640			
	A	B	t	単位質量 (kg/mt)	A	B	t	単位質量 (kg/mt)
	10	18	2	0.185	8	5.5	1	0.053
	20	35	2.4	0.455	10	7.5	1	0.069
	15	30	2	0.302	10	8	1	0.071
	40	75	3.2	1.293	10	10	1	0.076
	65	125	6	3.966	15	10	1	0.103
	※75	150	8	6.180	10	12	1	0.082
					11	14	1	0.092
					20	8.5	1.5	0.186
					12	18	1	0.109
					13	22	1	0.125
					15	27	1	0.150
					15	32	1	0.163

● アンゲル A6063 T5

☆は L=3,640 ※は L=4,000

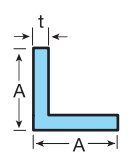
Rなし	等辺アンゲル L=4,000				B2 付アンゲル			
	A	A	t	単位質量 (kg/mt)	A	A	t	単位質量 (kg/mt)
 	10	10	1.2	0.061	☆ 9	9	0.8	0.037
	15	15	2	0.152	☆ 12	12	0.8	0.050
	15	15	3	0.220	☆ 15	15	0.8	0.064
	20	20	1.5	0.157	☆ 19	19	0.8	0.081
	60	60	6	1.860	☆ 25	25	0.8	0.107
	65	65	6	2.024	☆ 30	30	0.8	0.129
	100	100	10	5.168	※ 50	50	1.3	0.349
					※ 30	30	1.4	0.223
					※ 45	45	1.5	0.361
					※ 60	60	2	0.642
					※ 70	70	2.2	0.825
					※ 80	80	2.3	0.987
					B2 付不等辺アンゲル			単位質量 (kg/mt)
					A	B	t	
					☆ 6	12	1.2	
				☆ 6	18	1	0.063	
				※ 10	25	1.5	0.137	
				※ 10	30	1.5	0.157	
				※ 10	40	1.5	0.198	
				※ 15	20	1.4	0.128	
				※ 15	20	2	0.180	

取り寄せ品

*丸管

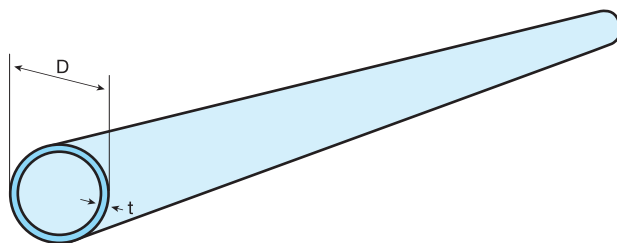

◎印▷A6063TD
 ☆印▷A5052TD-H34

外 径 (D)	肉 厚 (t)								
	5	6	7	8	8.75	9	10	12	14
62			☆						
72			☆						
77			☆						
82		☆	☆	☆					
87		☆							
100			☆						
102		☆	☆	☆					
112				☆					
120			☆						
122		☆	☆	☆					
132				☆					
142				☆					
152				☆			☆		
160	◎ 5000L								
162				☆					
180	◎ 4000L								
183						☆			
200	◎ 4000L								
203					☆		☆		☆
220		◎ 3000L							
222							☆		
253								☆	